

VideoBloX Twisted Pair Video Solution

Unshielded Twisted Pair cabling is a proven installation method that can reduce the cost of a CCTV system and provide high immunity to interference. Honeywell's solution with active video transmitters and video input module with built in active UTP receiver, allows for direct connection to UTP cabling via a simple RJ45 connector.

HVB16TPTX UTP Video Transmitter (Converts Coax to UTP)

The HVB16TPTX is an active video transmitter that provides for connection of 16 cameras using conventional coaxial cable with BNC connectors and converts the video signal for connection to unshielded twisted pair (UTP). The twisted pair connections are RJ45 sockets. Each RJ45 socket provides 4 video outputs for twisted pair cabling and allows simple connection to a punch-down block.

A switch is provided on the front panel for each video input channel for selection of short cable distances (0-1500 feet) and long cable distances (1500-3000 feet).

Figure 1 HVB16TPTX Typical Installation

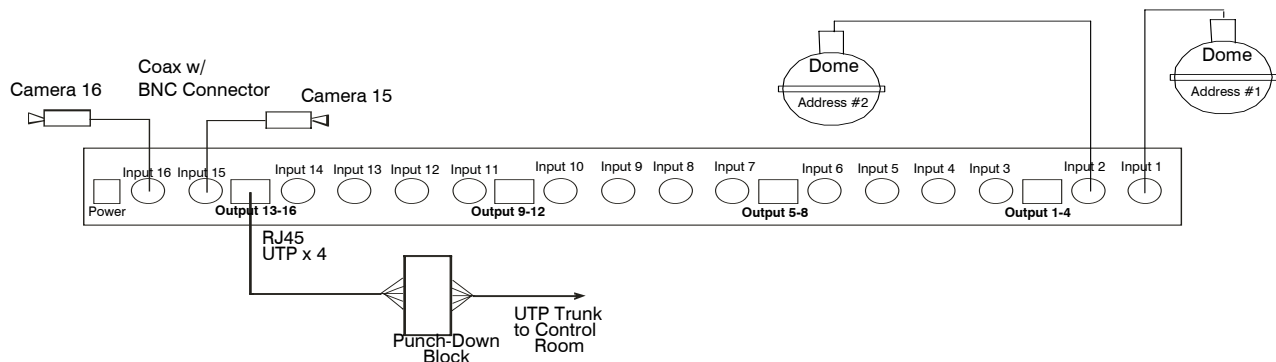

HVB16M64TP/HVB16M64ATP UTP Video Input Modules

The Video Input Modules provide the source of the video for the VideoBloX Cross Point Matrix Switch as well as direct video outputs for DVRs and similar devices. Installed in the matrix chassis, each occupying only a single 1/2U slot, they are position independent and are hot-swappable while the switched is powered on. Fabricated from stainless steel, the faceplate and rear termination panels provide both a sophisticated look and improved grounding to reduce static problems. Manufactured from the highest quality components and using surface mount technology, the modules provide near broadcast quality video with minimum degradation. Advanced circuitry provides protection against over-voltage and on-board power supplies provide uniform power and evenly distributed heat dissipation.

HVB16M64TP Video Input Modules with UTP have capacity for 16 video inputs connected to four (4) RJ45 sockets. Sixteen (16) BNC outputs allow the video signal to be looped through for connection to other devices such as monitors, DVRs or Enterprise DVRs. Connections do not have to be made at the loop-through connectors for proper operation of video switching.

HVB16M64ATP Video Input Modules with UTP have capacity for 16 video inputs connected to four (4) RJ45 sockets. A ribbon connector (for all 16 outputs) is provided for looping video inputs to another chassis for the purpose of extending the number of video outputs. The ribbon cable does not have to be connected for proper operation of video switching.

The front panel includes power and communication diagnostic LEDs for the module and individual Video Present blue LED's for each channel. A switch for each channel allows for selection of short (1,500 ft / 500 meters) or long (3,000 ft / 1,000 meters) distance applications. A gain adjustment potentiometer provides fine adjustment of the video signal. The modules are available as 16 inputs switched into 64 outputs.

Figure 2 HVB16M64TP Front Panel



Figure 3 HVB16TPTX Connected Directly to HVB16M64TP/HVB16M64ATP

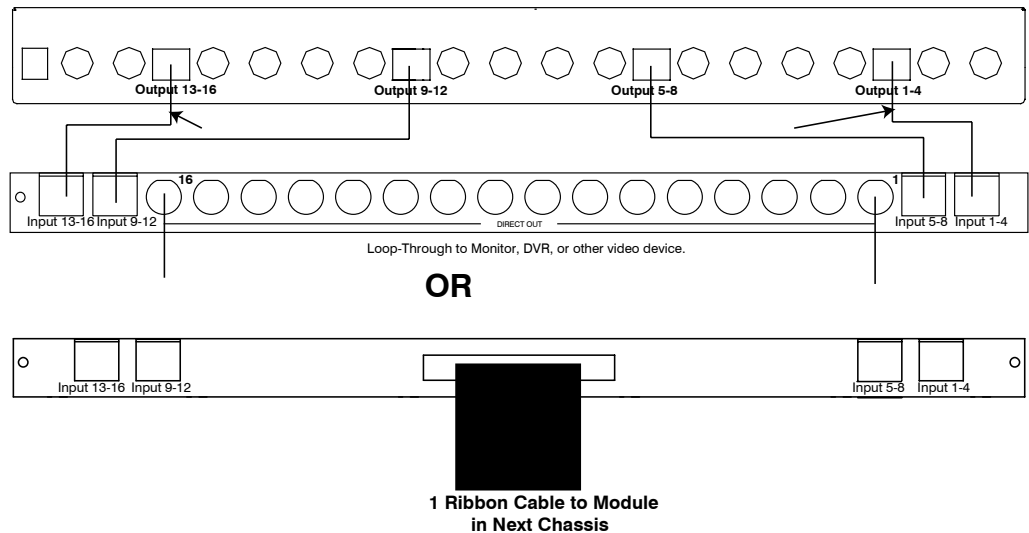

Notes The same connections are made at the RJ45 Inputs if UTP wiring is coming from a punch down block instead of directly from the HVB16TPTX Transmitter.

If the dome, such as an HD6 with UTP interface board, or the cameras are UTP compatible, the UTP wiring can be connected directly between the domes/cameras and the HVB16M64TP/HVB16M64ATP Video Input Modules. Refer to your dome/camera user manual for UTP cabling limitations/switch settings.

For detailed settings of the HVB16M64TP input module, please refer to its installation manual.