

MATRIX SWITCH with Single Chassis and HVBNET16CPU

Overview

This application note introduces the use of a matrix switch utilizing the HVBNET16CPU with the VideoBloX video switching hardware. This configuration uses the HVBGPIO for communications between the CPU and switching hardware as well as providing the PTZ control data.

The use of the HVBGPIO reduces the required hardware and cabling for communications between the CPU and control of PTZ devices.

This application note provides a sample application for use of the HVBNET16CPU with VideoBloX switching hardware. Please consult your Honeywell sales professional for assistance with your specific application.

Model Numbers

- HVBNET16CPU – Matrix Switch Embedded CPU
 - HVB2U, HVB4U, HVB8U or HVB12U Matrix Switch Chassis
 - HVBGPIO General Purpose I/O Card
 - HVBMxx Video Input Cards
 - HVBNET16TO Monitor Output Card with Text Overlay (Optional)
 - HJC5000 Operator Joystick Controller
 - HDCD8TP PTZ Data Distribution Device
-

Basic Installation Instructions

- Install Chassis' with cards.
- Install Operator Joystick Controller
- Power equipment.
- Program CPUs for operation

System Diagram #1 – Controller Attached to CPU

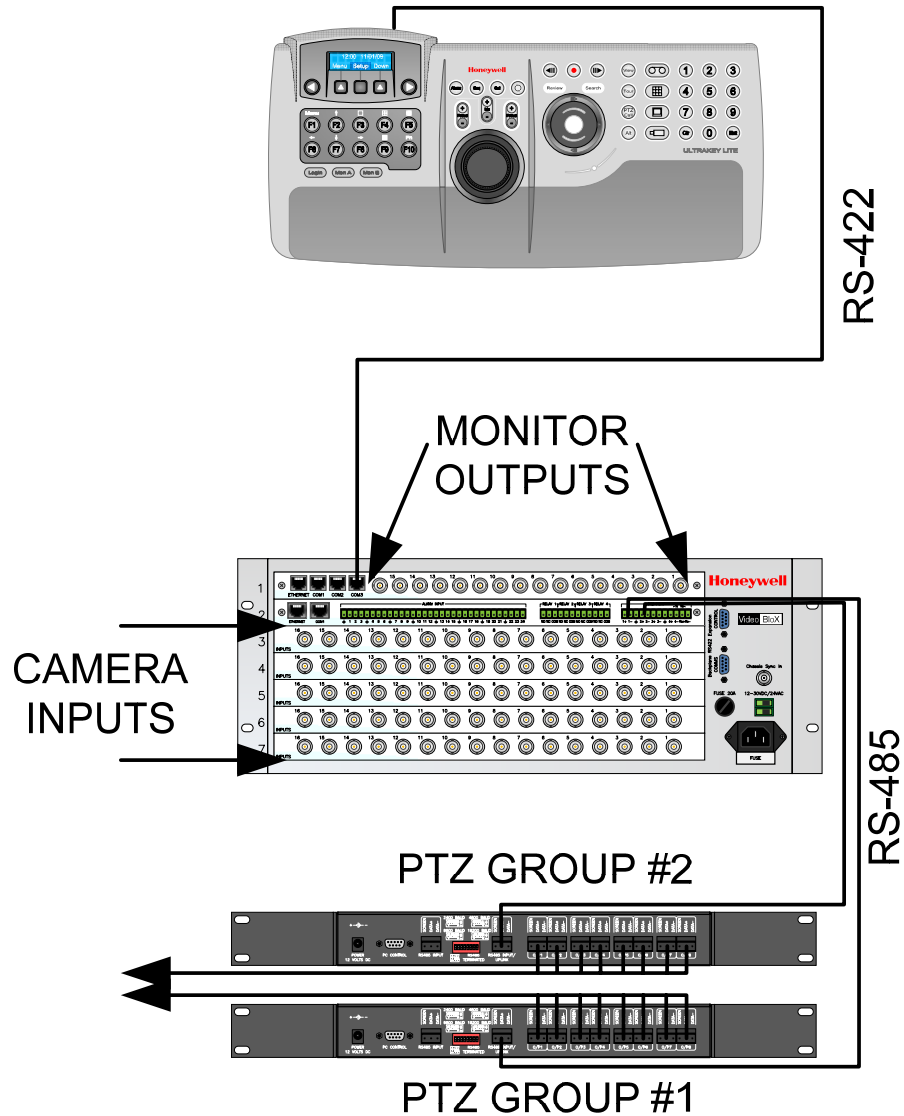

4 PTZ Groups can have up to 128 PTZ devices connected each – PTZ Data distribution shown for 8 PTZ devices per channel.

Note: When connecting the joystick/controller directly to the HVBNETCPU, there is a limit of one joystick/controller.

System Diagram #2 – Multiple Controllers to CPU – Direct

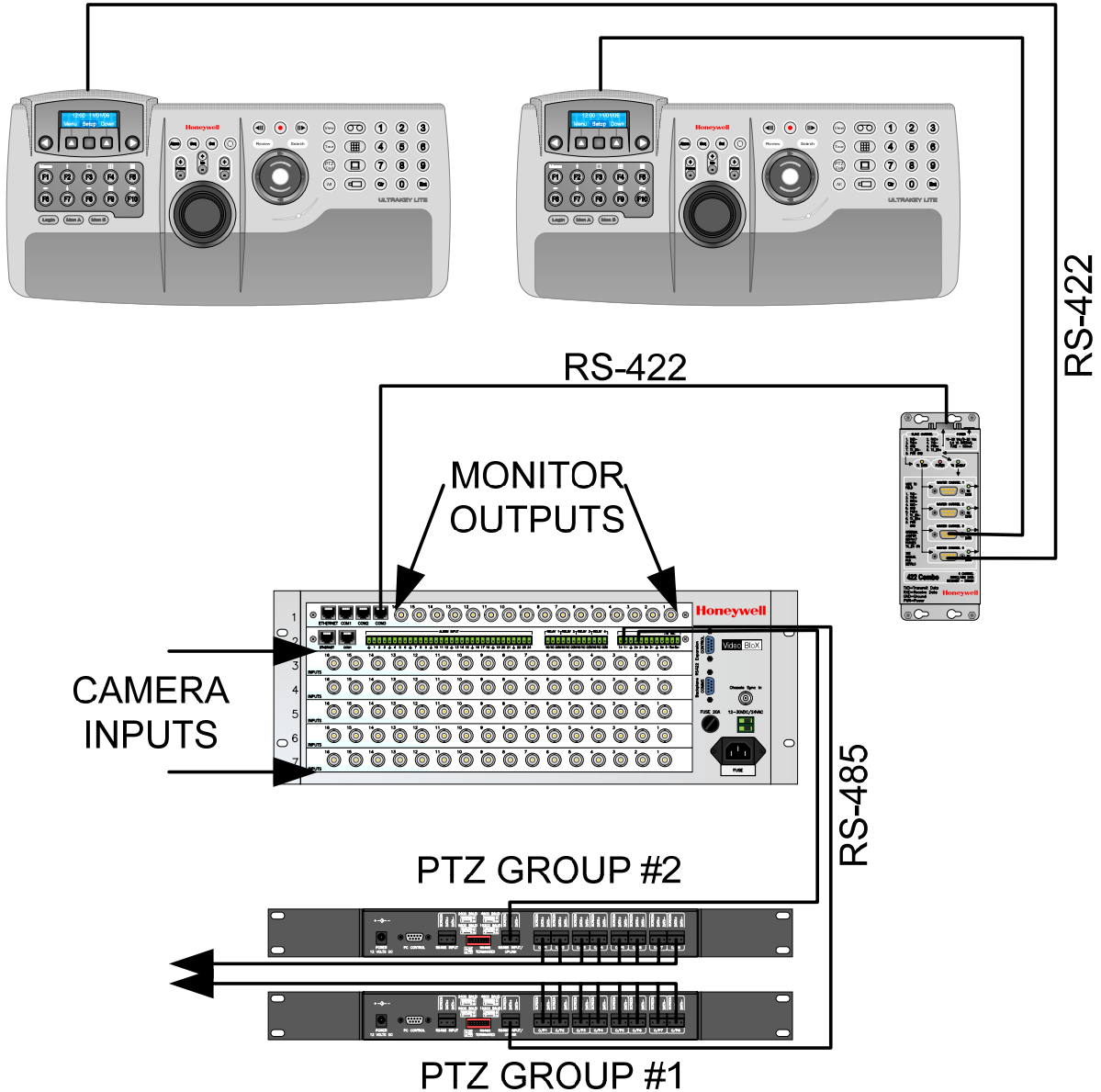

4 PTZ Groups can have up to 128 PTZ devices connected each – PTZ Data distribution shown for 8 PTZ devices per channel.

System Diagram #3 – Multiple Controllers to CPU – Network

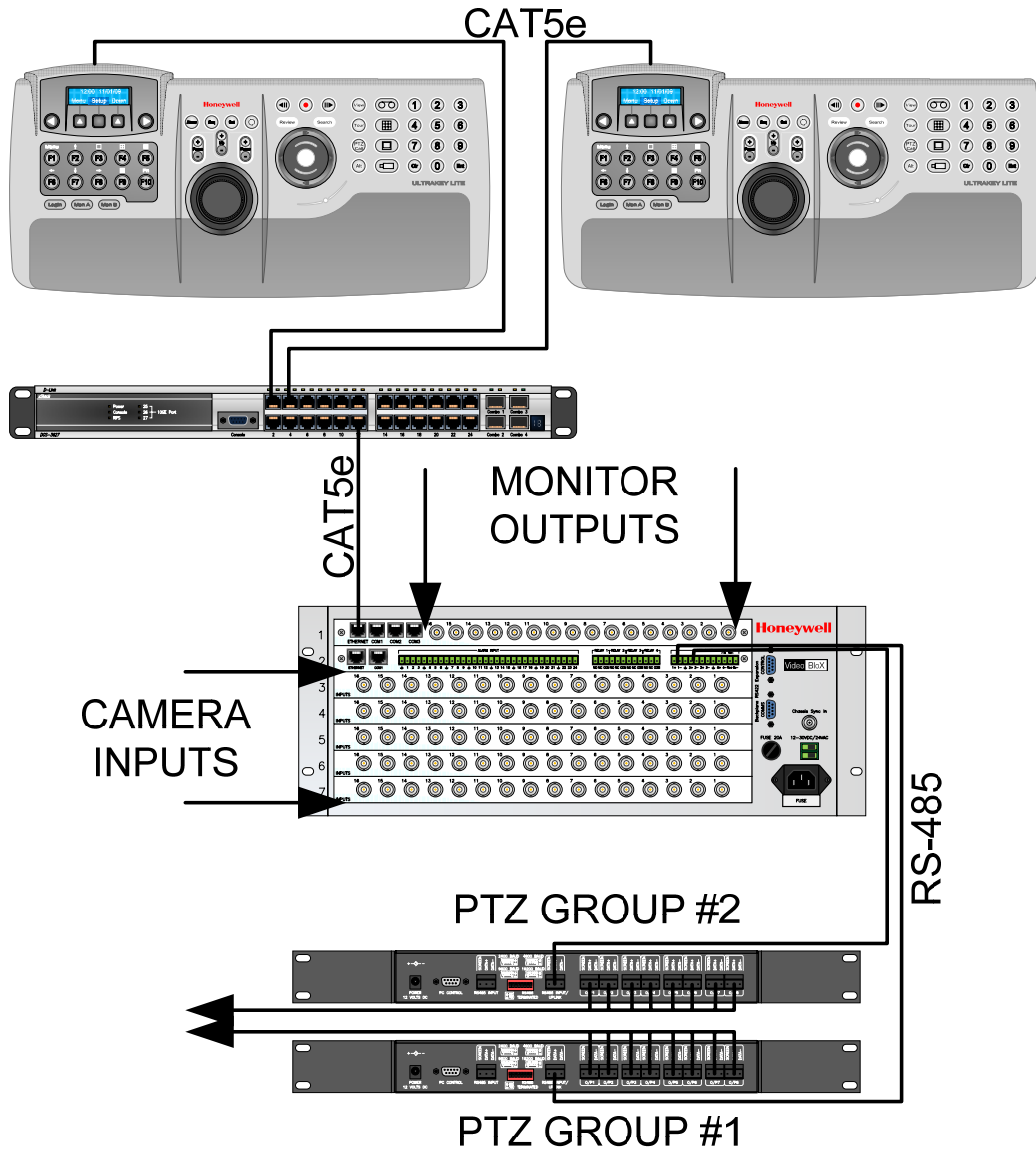

4 PTZ Groups can have up to 128 PTZ devices connected each – PTZ Data distribution shown for 8 PTZ devices per channel.

Note: Even though you may use a network for joystick/controller connection, the video is output from the matrix switch in analog format. To get the video to the monitoring location via network requires an encoder/decoder pair – not included with the matrix switch.

System Diagram #4 – Maximum Input Sizes – Single Chassis

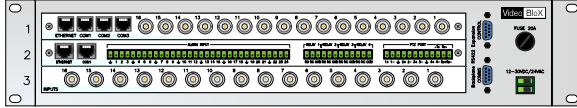

HVB2U – 16 Inputs with 16 Outputs

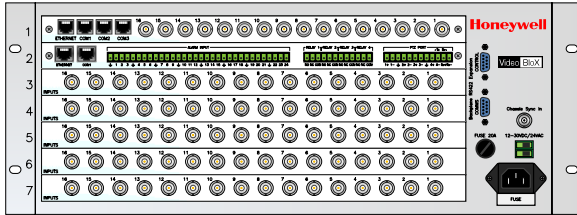

HVB4U – 80 Inputs with 16 Outputs

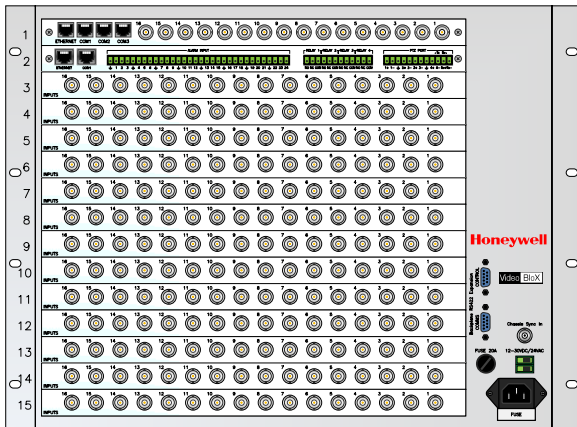

HVB8U – 208 Inputs with 16 Outputs

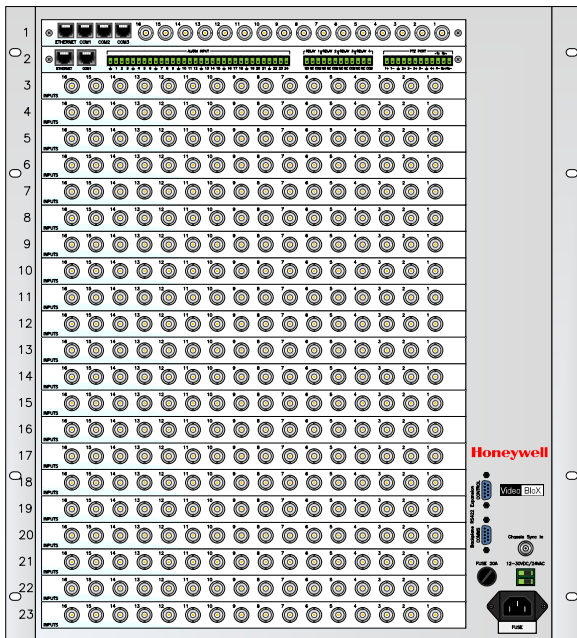

HVB12U – 336 Inputs with 16 Outputs

System Diagram #5 – Maximum Output Sizes – Single Chassis

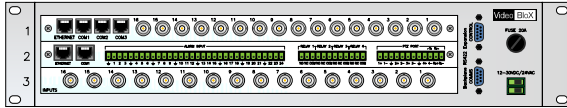

HVB2U – 16 Inputs with 16 Outputs

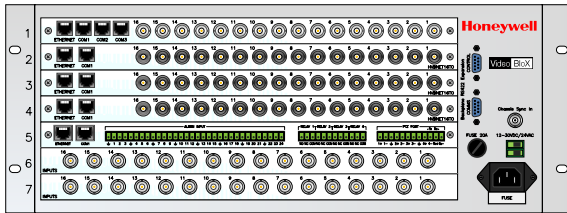

HVB4U – 32 Inputs with 64 Outputs

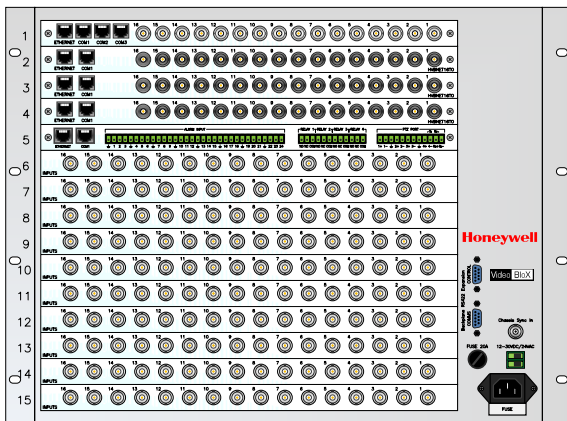

HVB8U – 160 Inputs with 64 Outputs

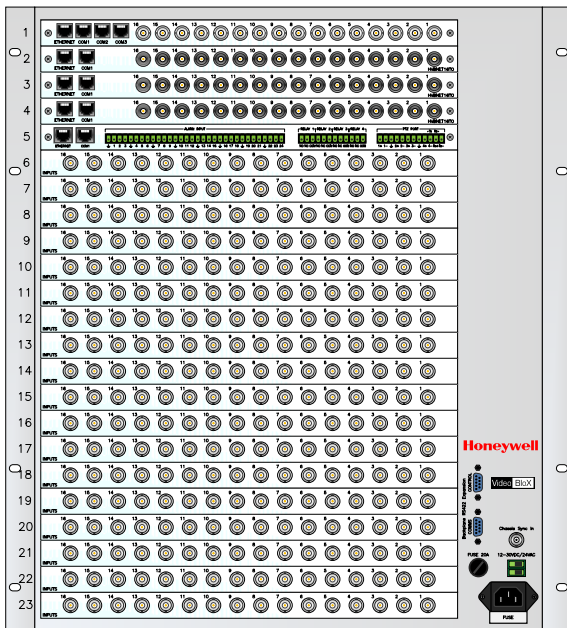

HVB12U – 288 Inputs with 64 Outputs

Honeywell

www.honeywellvideo.com

Honeywell Security
2700 Blankenbaker Pkwy.
Suite 15
Louisville, KY 40299

+1.800.796.CCTV (North America only)
HVSsupport@honeywell.com