

HCS554IP

EQUIP™ SERIES DAY/NIGHT NETWORK CAMERA

Honeywell's EQUIP™ Series is an array of IP-based products that have an open architecture platform and utilize a single Application Program Interface (API). The API allows for a common user experience and integration with hybrid Digital Video Recorders (DVRs) and Network Video Recorders (NVRs).

The Honeywell HCS554IP day/night network camera offers the latest in digital video surveillance. The 1/3" CCD network camera combines world-class video performance with the EQUIP Series IP networking technology providing streaming MPEG-4 images in 4CIF, 2CIF, or CIF resolutions with rates up to 30 frames per second (25 fps for PAL systems).

The HCS554IP day/night camera adapts to varying lighting conditions to ensure high picture quality even in extreme low light conditions. When the light level drops too low for accurate video identification in color, the camera automatically switches to black and white video to capture more detail. For additional control, the on-board alarm input can be configured to switch the camera from day to night mode to allow synchronized with external lighting.

The HCS554IP has built-in Power over Ethernet (IEEE 802.3af), which allows power to be supplied to the camera using the network, eliminating the need for a separate power supply and reducing the cost of installation. For additional installation flexibility the unit can also be powered with 12 VDC or 24 VAC.

Market Opportunities

The HCS554IP is a network surveillance solution designed for object recognition that is required in locations where variable light conditions exist. Setup is quick and easy and can be customized through a Web client or from an NVR. This provides optimum performance for both indoor and outdoor applications.

Features

- 4CIF, 2CIF, or CIF resolutions
- 1/3" color CCD, 540 TVL
- Excellent low light performance, down to 0.5 lux
- Camera Sabotage Detection
- MPEG-4 compression
- Remote firmware updates
- Supports both Dynamic and Static IP addresses
- Variable day/night threshold setting to accommodate switching to black and white images in low light
- Multiple levels of password protected remote access prevents unauthorized users from altering system settings
- Includes advanced IP locator software to make system setup easy
- Web server for remote setup of camera video and network parameters
- 12 VDC/24 VAC or PoE IEEE 802.3af choice of power inputs
- Supports CS mount lenses
- Supports two-way audio



HCS554IP

SPECIFICATIONS

Like all cameras in the EQUIP Series, the HCS554IP uses Honeywell proprietary technology for camera sabotage detection, remote firmware updating and for secure storage of all camera settings. Camera sabotage detection notifies the user when a camera's field of view is altered, blinded or blurred. This ensures the video's integrity and alerts the customer to either a live event or a system problem that is causing disruption to the video stream. Honeywell's technology also allows users to remotely upload firmware to the camera. Setup is quick and easy and can be customized through a Web client or from an NVR or DVR. The built-in Web server provides password protected access to the camera's video and network setup.

System Diagram

Internet Explorer or Honeywell IT Utility

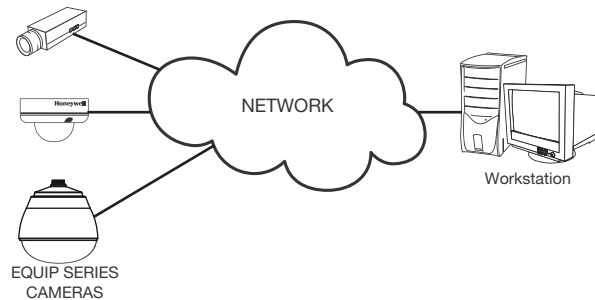

Hybrid DVR or NVR

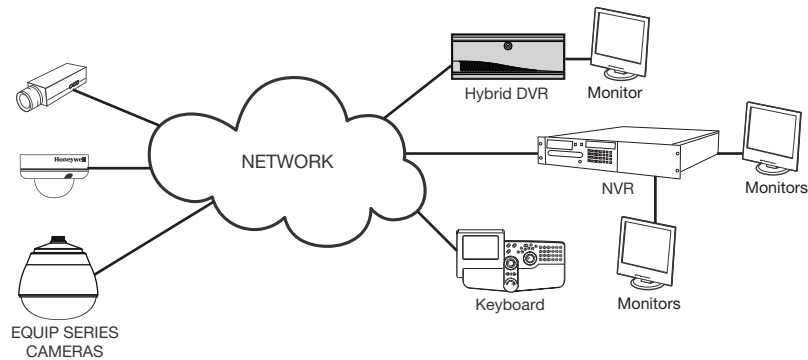

HCS554IP

SPECIFICATIONS

Operational													
Video Standard	NTSC, PAL												
Scanning System	525/60 lines (NTSC), 625/50 lines (PAL)												
Image Sensor	1/3" CCD												
Number of Pixels (H x V)	HCS554IP: 768 x 494 (NTSC) HCS554IPX: 752 x 582 (PAL)												
Minimum Illumination	0.7 lux color/0.5 lux BW @ 50 IRE, F1.2 0.25 lux color/0.18 lux BW @ 30 IRE, F1.2												
Horizontal Resolution	Greater than 540 TVL												
Automatic Lens Control	DC Iris Level 1-25												
Video Output	1.0 Vp-p @ 75 Ohms												
S/N Ratio	50 dB or more (AGC off)												
Auto Gain Control	Off/On, selectable (10-30 dB)												
Automatic Electronic Shutter	1/60-1/100,000 sec (NTSC) 1/50-1/100,000 sec (PAL)												
White Balance	ATW, User Fixed, AWC (Auto or Manual), Fluorescent, MWB (Manual Mode), Indoor, Outdoor												
Back Light Compensation	Off/On, selectable												
Gamma	0.45												
Audio/Two-Way	Line in/out												
Electrical													
Input Voltage	12 VDC/24 VAC, PoE IEEE 802.3af												
Input Range	11-16 VDC, 17-28 VAC												
Surge Suppression	1.5 kW transient												
Power Consumption	8 W (max)												
Mechanical													
Dimensions (W x H x D)	See Diagram												
Weight	1.1 lb (.5 kg) camera only												
Construction	Housing: Aluminum Finish: Cool Gray Powder Coat												
Camera Mount	1/4-20 UNC mounting ring												
Lens Mount	CS Lens Mount												
Connector	Video Output: BNC connector Lens: 4 Pin Connector Power Input: Removable screw block Network: RJ45 connector Alarm I/O: Removable screw block Audio In: 3.5 mm mono phone jack Audio Out: 3.5 mm mono phone jack												
Environmental													
Temperature	Operating: 14°F to 122°F (-10°C to 50°C) Storage: -4°F to 140°F (-20°C to 60°C)												
Relative Humidity	0% to 85%, non-condensing												
IP Specifications													
Video Compression	MPEG-4 Part 2 (ISO/IEC 14496-2) SP level 0-3												
Resolutions	<table border="1"> <thead> <tr> <th></th> <th>NTSC</th> <th>PAL</th> </tr> </thead> <tbody> <tr> <td>4CIF</td> <td>704 x 480</td> <td>704 x 576</td> </tr> <tr> <td>2CIF</td> <td>704 x 240</td> <td>704 x 288</td> </tr> <tr> <td>CIF</td> <td>352 x 240</td> <td>352 x 244</td> </tr> </tbody> </table>		NTSC	PAL	4CIF	704 x 480	704 x 576	2CIF	704 x 240	704 x 288	CIF	352 x 240	352 x 244
	NTSC	PAL											
4CIF	704 x 480	704 x 576											
2CIF	704 x 240	704 x 288											
CIF	352 x 240	352 x 244											
Frame Rate NTSC/PAL	Up to 30/25 fps video in all resolutions												
Video Streaming	MPEG-4 controllable frame rate and bandwidth. Constant or variable bit rate												
Security	Multiple user access levels with password protection												
Users	1 Administrator, 4 Guests (unicast)												
Video Access from Web Browser	Camera live view for up to 5 clients. Full control of all camera settings available to administrator												
Minimum Web Browsing Requirements	Pentium IV CPU 3.0 GHz or equivalent AMD, 512 MB RAM, AGP graphics card (32 MB RAM) Windows® XP 2000, Internet Explorer 6.0 or later												
Supported Protocols	IPv4, HTTP, TCP, RTSP, RTP, UDP, ARP, DNS, RTCP, FTP, ICMP, DHCP, Bonjour, IGMP												
Regulatory													
Emissions	FCC, CE (EN55013)												
Immunity	CE (EN50130-4)												
Safety	EU: 73/23/EEC LVD UL Listed (file E319174)												

SPECIFICATIONS

System Compatibility	
Hybrid DVRs	
Fusion III	Full Featured Hybrid Digital Video Recorder, version 3.6 or higher
NVRs	
Enterprise NVR Series	Enterprise Class Digital Network Video Recorder System, version 5.6 or higher
DVM	Digital Video Manager, version R200.2 or higher

Accessories	
Recommended Lens Options	
HLD25V6F12L	2.5-6 mm, F1.2, DC Auto Iris Lens
HLD28V8F95L	2.8-8 mm, F0.95, DC Auto Iris Lens
HLD27V13DNL	2.7-13.5 mm, F1.3, DC Auto Iris Lens, IR corrected
HLD5V50F13L	5.0-50 mm, F1.3, DC Auto Iris Lens
Housing and Mounts	
HBC5WT	Wall/ceiling mount bracket
HHC12 Series	Housing with optional heater/blower and mounts

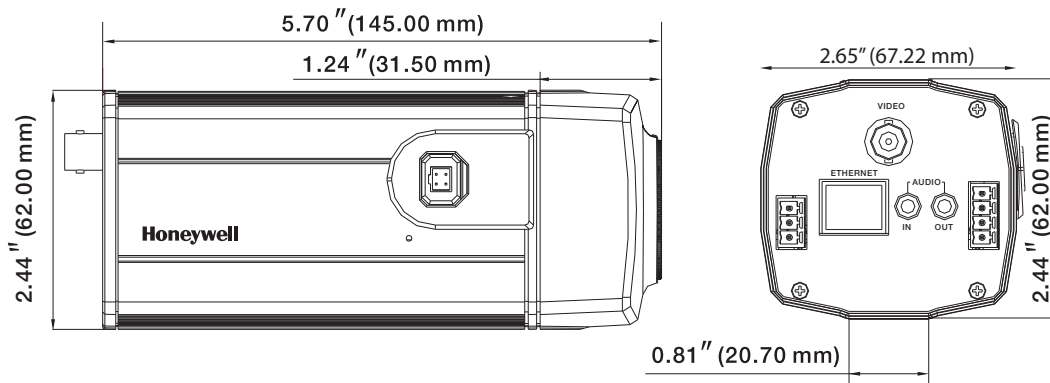

Ordering	
HCS554IP	EQUIP Series 1/3" CCD High Resolution Day/Night Camera with DSP, 540 TVL, 12 VDC/24 VAC or PoE IEEE 802.3af, NTSC
HCS554IPX	EQUIP Series 1/3" CCD High Resolution Day/Night Camera with DSP, 540 TVL, 12 VDC/24 VAC or PoE IEEE 802.3af, PAL

NOTE: Honeywell reserves the right, without notification, to make changes in product design or specifications.

Automation and Control Solutions

Honeywell Systems
 2700 Blankenbaker Pkwy, Suite 150
 Louisville, KY 40299
 1.800.323.4576
 www.honeywell.com

L/HCS554IP/D
 December 2008
 © 2008 Honeywell International Inc.