

HD4MDIP

EQUIP® SERIES 720P TRUE DAY/NIGHT RUGGED INDOOR/OUTDOOR DOME NETWORK CAMERA

Honeywell's latest addition to the EQUIP® Series of IP-based products, the HD4MDIP is a high definition, True Day/Night rugged indoor/outdoor fixed mini-dome camera. This ultra compact and vandal-resistant camera provides extremely crisp images at minimal bandwidth. The HD4MDIP provides 720p resolution at full frame rate. Progressive scan technology and 2D edge enhancement provide outstanding clarity and definition. Digital Noise Reduction results in significant storage savings without sacrificing image quality in low light. The 1/4" progressive scan CMOS sensor offers the latest in digital video surveillance technology with accurate color rendition through a wide variety of lighting conditions.

The HD4MDIP integrates a camera and lens in an ultra compact, single piece, tamper proof unit for fast and easy installation in any application. The camera comes complete with surface and flush mounting options (compatible with a 4S electrical box), and optional wall and pendant mount kits are available.

In addition to the low light color performance, the camera will automatically switch to black and white. In this mode, lighting can be complemented with infrared for discreet/covert low light surveillance with exceptional monochrome images.

A 3-D axis gimbal capable of 360° of pan, 180° of tilt and 360° of horizontal rotation simplifies mechanical camera adjustment. The Vari-focal Auto Iris lens allows the field of view to be adjusted to suit the scene requirements, and an on-board analog output allows the installer to connect a local test monitor while adjusting the scene.

A powerful and intuitive web client allows fine tuning of the camera. This can also be performed from most DVR/NVR setup utilities.

The HD4MDIP supports dual video streams and multiple compression formats with rates up to 30 frames per second (25 fps for PAL systems). The digital compression parameters for the two video streams are independently configurable. A third analog stream can be utilized for failover and local viewing, and is also valuable when retrofitting onto an existing analog input DVR or encoder (full resolution not available).

With built-in low current Power over Ethernet (IEEE 802.3af), Class 1, power is supplied to the camera using standard network cabling, eliminating the need for a separate power supply and associated wiring. In retrofit situations where PoE switching does not exist, the unit can also be powered directly from 24 VAC.

Market Opportunities

The HD4MDIP is perfect for installations where excellent picture clarity at minimal bandwidth is required. At three times the resolution of standard analog cameras, yet with similar bandwidth requirements, the HD4MDIP can be retrofitted on many existing DVR/NVR installations without requiring additional storage. Its discreet, vandal-resistant, outdoor design provides maximum protection against dust, dirt, and water, and is also impact resistant. This provides optimum performance for both indoor and outdoor applications.

Features

- Outstanding image quality, 720p (1280 X 720) resolution
- 30 fps (25 fps PAL) progressive scan
- True Day/Night, 3.3-12 mm VFAI lens with removable IR cut filter
- Camera tamper detection
- Video motion detection
- Wall and pendant mount kit available
- Selectable compression formats
- Dual digital video streams simultaneously, independently configurable
- Remote firmware update
- Supports both dynamic and static IP address assignment
- Includes advanced IP locator software to make system setup easy
- Web server for remote setup of camera video and network parameters
- Choice of 24 VAC or PoE IEEE 802.3af class 1 power inputs
- Supports input and output alarm contacts
- Supports bidirectional audio
- Rugged polycarbonate dome



HD4MDIP

SPECIFICATIONS

Like all cameras in the EQUIP Series, the HD4MDIP network camera uses Honeywell technology for camera video motion detection, tamper detection, remote firmware updating, and for secure storage of all camera settings. Video motion detection recognizes object motion within the field of view; then a simple on-screen notification alerts the user. Camera tamper detection notifies the user when a camera's field of view is altered, obstructed, or blurred. This ensures the video's integrity and alerts the customer to either a live event or a system problem that is causing disruption to the video stream. Honeywell's technology also allows users to remotely upload firmware to the camera. Setup is quick and easy and can be customized through a web client or from an NVR or DVR. The built-in web server provides password protected access to the camera's video and network setup.

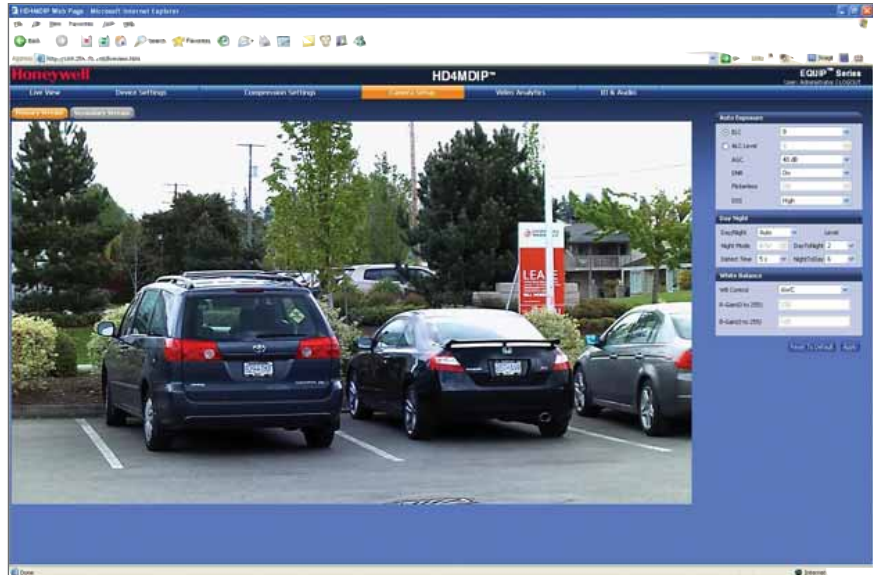

System Diagram

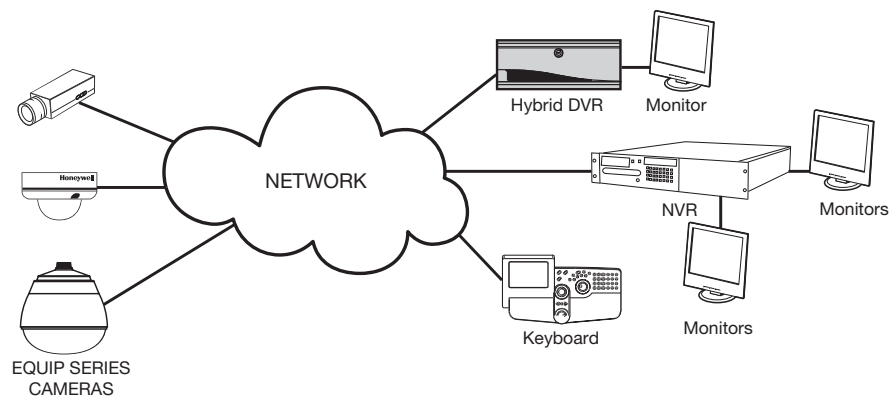

HD4MDIP

SPECIFICATIONS

Operational		Environmental			
Video Standard	NTSC, PAL	Temperature	Operating: -22°F to 140°F (-30°C to 60°C) Storage: -4°F to 140°F (-20°C to 60°C)		
Scanning System	Progressive scan	Relative Humidity	0% to 85%, non-condensing		
Image Sensor	1/4" CMOS	Rating	IP66		
Number of Pixels (H x V)	1280 x 720	IP Specifications			
Minimum Illumination	0.25 lux color/0.22 lux BW @ 50 IRE, F1.6 0.11 lux color/0.09 lux BW @ 30 IRE, F1.6	Video Compression	Industry standard compression		
Automatic Lens Control	DC Iris Level 1-25	Resolutions	Bit Rate (Typical)*	Frame Rate	Storage/Day (GB)
Video Output (AUX)	1.0 Vp-p @ 75 Ohms	1280 x 720	3 Mbps	30/25	31.64
S/N Ratio	50 dB or more (AGC off)	800 x 450	2 Mbps	30/25	21.09
Auto Gain Control	Off/On, selectable (10-40 dB)	640 x 360	1 Mbps	30/25	10.55
Automatic Electronic Shutter	1/60-1/24,500 (NTSC) 1/50-1/24,500 (PAL)	320 x 180	0.35 Mbps	30/25	3.69
Lens Type	True Day/Night (TDN), 3.3-12.0 mm Vari-focal Auto Iris, F1.6	Frame Rate NTSC/PAL	Up to 30/25 fps		
White Balance	AWC, AWC Push, Manual	Video Streaming	Dual streaming: MPEG-4 and MJPEG Controllable frame rate and bandwidth Constant or variable bit rate (MPEG-4)		
Audio/Two-Way	Line in/out	Security	Multiple user access levels with password protection		
Electrical		Users	1 Administrator or 1 Guest		
Input Voltage	24 VAC, PoE IEEE 802.3af, Class 1	Video Access from Web Browser	Camera live view for 1 client. Full control of all camera settings available to administrator		
Input Range	17-28 VAC	Minimum Web Browsing Requirements	Pentium IV CPU 3.1 GHz or equivalent AMD, 1 GB RAM, AGP graphics card (32 MB RAM) Windows® XP/2003, Internet Explorer 6.0 or later		
Surge Suppression	1.5 kW transient	Installation and Management Maintenance	Honeywell IP Utility software identifies the IP address, checks status of device, Firmware upgrades over HTTP		
Power Consumption	3.5 W (max)	Supported Protocols	HTTP, TCP, RTSP, RTP, UDP, ARP, DNS, RTCP, FTP, ICMP, DHCP, Bonjour, IGMP, Telnet		
Mechanical		Regulatory			
Dimensions (W x H x D)	See Diagram	Emissions	FCC, CE (EN55022)		
Weight	3.0 lb (1.3 kg) camera only	Immunity	CE (EN55024)		
Construction	Housing: Die cast Aluminum Finish: Cool Gray Powder Coat Dome: Polycarbonate	Safety	EU: LVD 2006/95/EC, UL60950		
Connector	Video Output (AUX): 2-pin Molex connector Power Input: Removable screw block Alarm I/O: Removable screw block Network: RJ45 connector Audio In: Removable screw block Audio Out: Removable screw block	* Actual bit rate is scene and motion dependent			

SPECIFICATIONS

System Compatibility	
Honeywell Products	
Hybrid DVRs	
Fusion IV	Full Featured Hybrid Digital Video Recorder, v4.00.6405 or higher
NVRs	
Enterprise NVR Series	Enterprise Class Digital Network Video Recorder System, version 5.75 build 19 or higher
MAXPRO VMS/IP Engine	v R200 SP1 or higher
Fusion IV	v4.00.6405 or higher
Third-Party Products	
Refer to the Honeywell Open Technology Alliance for a comprehensive list of compatible products to which this device is integrated.	
Accessories	
Housing and Mounts	
HD4DIP-PK	Pendant Mount Bracket
HD4DIP-WK	Wall Mount Bracket

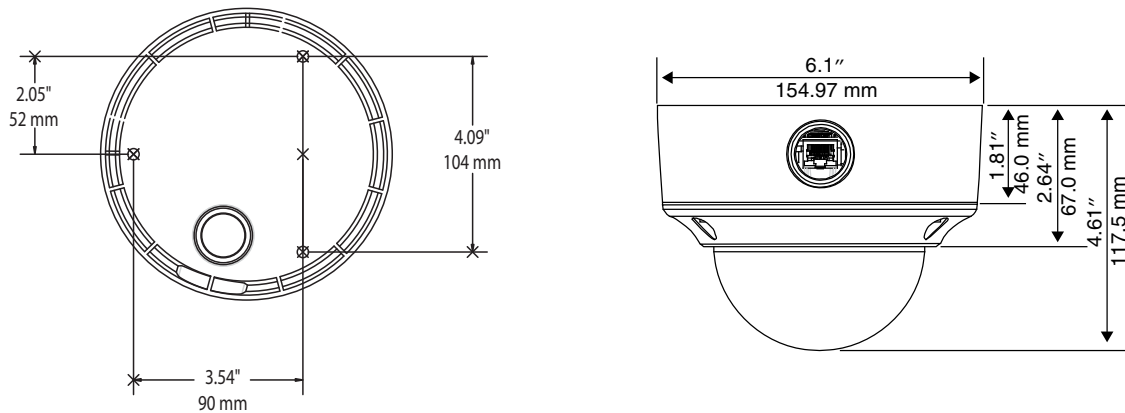

Ordering	
HD4MDIP	Network, True Day/Night Rugged Fixed Dome, 1/4" Progressive Scan, CMOS, 720p Resolution Camera, 3.3-12 mm VFAI, 24 VAC or PoE IEEE 802.3af, NTSC
HD4MDIPX	Network, True Day/Night Rugged Fixed Dome, 1/4" Progressive Scan, CMOS, 720p Resolution Camera, 3.3-12 mm VFAI, 24 VAC or PoE IEEE 802.3af, PAL

NOTE: Honeywell reserves the right, without notification, to make changes in product design or specifications.

Automation and Control Solutions

Honeywell Systems
 2700 Blankenbaker Pkwy, Suite 150
 Louisville, KY 40299
 1.800.796.2288
 www.honeywell.com

