

HD55IP

PERFORMANCE SERIES 720P DAY/NIGHT H.264 RUGGED INDOOR/OUTDOOR FIXED MINI-DOME IP CAMERA

Honeywell's latest addition to the Performance Series of IP-based products, the HD55IP is a 720p resolution, day/night rugged indoor/outdoor fixed mini-dome network camera engineered to provide extremely crisp images at minimal bandwidth. The HD55IP provides 720p resolution at full frame rate. Progressive scan technology and 2D edge enhancement provide outstanding clarity and definition. Digital Noise Reduction results in significant storage savings without sacrificing image quality in low light. The 1/4" progressive scan CMOS sensor offers the latest in digital video surveillance technology with accurate color rendition under a wide variety of lighting conditions. The HD55IP also supports the PSIA specification for interoperability between network video products.

The HD55IP integrates a camera and lens in an ultra compact, single piece, vandal-resistant unit for fast and easy installation in any application. The camera is designed to be surface mounted. Wall and pendant mount kits are also available.

A 3-D axis gimbal capable of 360° of pan, 180° of tilt and 360° of horizontal rotation simplifies mechanical camera adjustment. The vari-focal auto iris lens allows the field of view to be adjusted to suit the scene requirements, and an integrated analog output is provided for the installer to connect to a local test monitor while adjusting the scene.

A powerful and intuitive web client allows fine tuning of the camera and the auto iris levels

The HD55IP supports dual video streams and multiple compression formats with rates up to 30 frames per second (25 fps for PAL systems). The digital compression parameters for the two video streams are independently configurable. A third analog stream can be utilized as backup or for local viewing. It is also valuable when retrofitting onto an existing analog input DVR or encoder (full resolution not available).

With built-in low current Power over Ethernet (IEEE 802.3af), Class 1, power is supplied to the camera using standard network cabling, eliminating the need for a separate power supply and associated wiring. In retrofit situations where PoE switching does not exist, the unit can also be powered directly from 24 VAC.

Market Opportunities

The HD55IP is perfect for installations where excellent picture clarity at minimal bandwidth is required. At three times the resolution of standard analog cameras, yet with similar bandwidth requirements, the HD55IP can be retrofitted on many existing DVR/NVR installations without requiring additional storage. Its discreet, vandal-resistant, outdoor design is impact resistant and offers maximum protection against dust, dirt, and water. This provides optimum performance for both indoor and outdoor applications.

Key Benefits

- Outstanding image quality, 720p (1280 x 720) resolution
- 30 fps (25 fps PAL) progressive scan
- Day/Night, 3.3-12 mm VFAL lens
- Camera tamper detection
- Video motion detection
- PSIA support
- Simultaneous, dual video streams, independently configurable
- Remote firmware updates
- Supports both dynamic and static IP address assignment
- Single model for surface mount applications
- Includes advanced IP locator software to make system setup easy
- Web server for remote setup of camera video and network parameters
- Choice of 24 VAC or PoE IEEE 802.3af Class 1 power inputs
- Rugged polycarbonate dome
- Wall and pendant mount kits available



HD551P

SPECIFICATIONS

Like all cameras in the Performance Series, the HD551P network camera uses Honeywell technology for camera video motion detection, tamper detection, remote firmware updating and for secure storage of all camera settings. Video motion detection recognizes object motion within the field of view; then a simple on-screen notification alerts the user. Camera tamper detection notifies the user when a camera's field of view is altered, blinded, or blurred. This ensures the video's integrity and alerts the customer to either a live event or a system problem that is causing disruption to the video stream. Honeywell's technology also allows users to remotely upload firmware to the camera. Setup is quick and easy and can be customized through a web client or from an NVR or DVR. The built-in web server provides password-protected access to the camera's video and network setup.

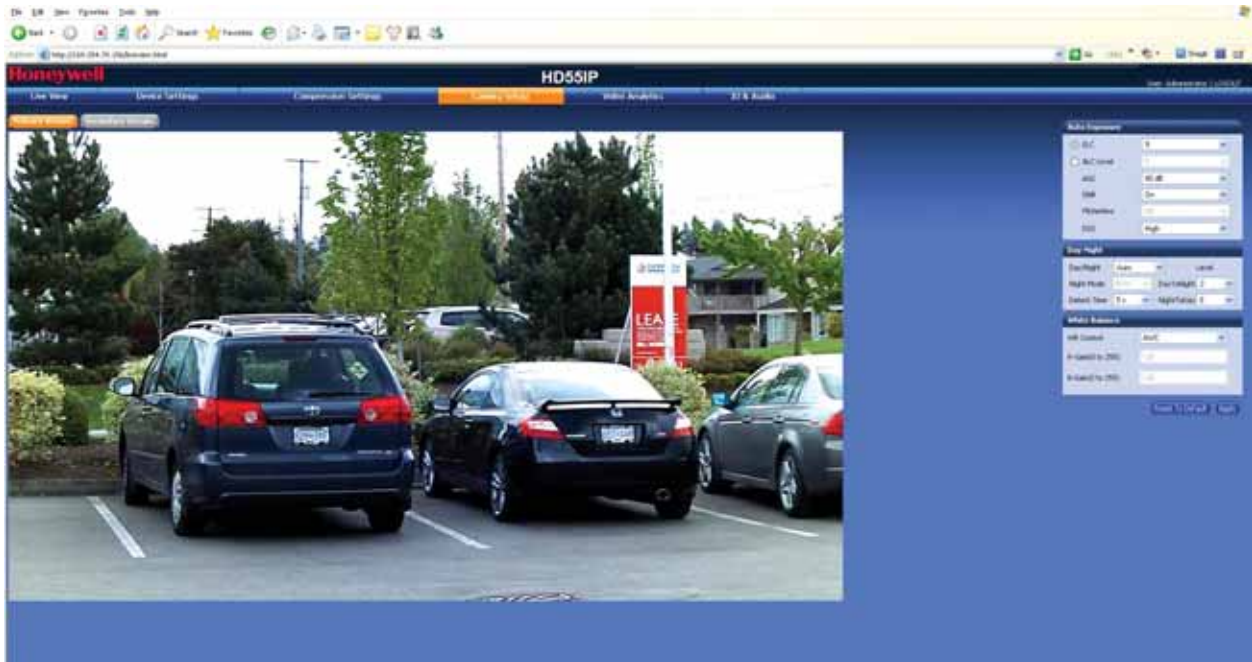

SYSTEM DIAGRAM

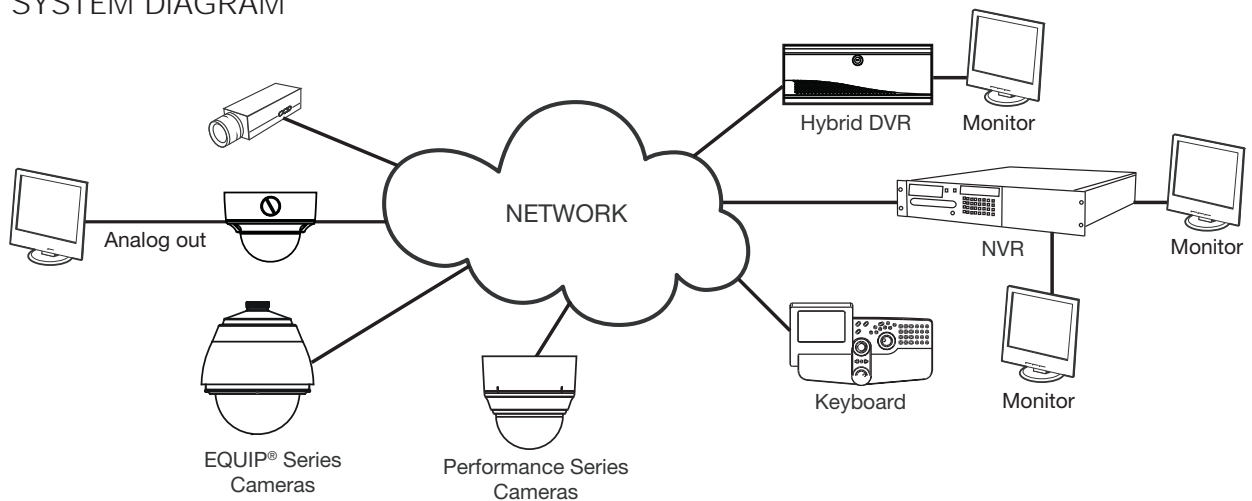

SPECIFICATIONS

Operational	
Video Standard	NTSC, PAL
Scanning System	Progressive scan
Image Sensor	1/4" CMOS
Number of Pixels (H x V)	1280 x 720
Minimum Illumination	0.25 lux @ 50 IRE, F1.6 0.11 lux @ 30 IRE, F1.6
Automatic Lens Control	DC Iris Level 1-25
Video Output (Aux)	1.0 Vp-p @ 75 ohms
S/N Ratio	50 dB or more (AGC off)
Auto Gain Control	Off/On, selectable (10-40 dB)
Automatic Electronic Shutter	1/60-1/24,500 sec (NTSC) 1/50-1/24,500 sec (PAL)
Lens Type	3.3-12 mm Vari-focal Auto Iris, F1.6
White Balance	AWC, AWC Push, Manual
Electrical	
Input Voltage	24 VAC, PoE IEEE 802.3af, Class 1
Input Range	17-28 VAC
Surge Suppression	1.5 kW transient
Power Consumption	3.5 W (max)
Mechanical	
Dimensions (W x H x D)	See Diagram
Weight	3.0 lb (1.3 kg) camera only
Construction	Housing: Die cast Aluminum Finish: Cool Gray Powder Coat Dome: Polycarbonate
Connector	Video Output (AUX): 2-pin Molex connector Power Input: Removable screw block Network: RJ45 connector

Environmental			
Temperature	Operating: -4°F to 122°F (-20°C to 50°C) Storage: -40°F to 158°F (-40°C to 70°C)		
Relative Humidity	0% to 85%, non-condensing		
Rating	IP66		
IP Specifications			
Video Compression	Dual stream H.264 and MJPEG		
Resolutions	H.264 Bitrate (Typical)*	Frame Rate	Storage/Day (GB)
1280 x 720	1.8 Mbps	30/25	18.98
800 x 450	1.2 Mbps	30/25	12.65
640 x 360	0.6 Mbps	30/25	6.33
320 x 180	0.21 Mbps	30/25	0.89
Frame Rate NTSC/PAL	Up to 30/25 fps video in all resolutions		
Video Streaming	Dual streaming: H.264 and MJPEG Controllable frame rate and bandwidth		
Security	Multiple user access levels with password protection		
Users	1 Administrator, 3 Guests		
Video Access from Web Browser	Full control of all camera settings available to administrator		
Minimum Web Browsing Requirements	Pentium IV CPU 3.1 GHz or equivalent AMD, 1 GB RAM, AGP graphics card (32 MB RAM) Windows® 7 (32-bit and 64-bit), Windows® XP, Windows® Server® 2008 R2, Internet Explorer 6.0 or later		
Installation and Management Maintenance	Honeywell IP Utility software identifies the IP address, checks status of device, firmware upgrades over HTTP		
Supported Protocols	HTTP, TCP, RTSP, RTP, UDP, ARP, DNS, RTCP, FTP, ICMP, DHCP, Bonjour, IGMP, Telnet		
Standards	PSIA support		
Regulatory			
Emissions	FCC, CE (EN55022)		
Immunity	CE (EN55024)		
Safety	EU: 2001/95/EC GPSD, UL 60950-1		

*Actual bitrate is scene and motion dependent.

SPECIFICATIONS

System Integration
Open IP Integration
PSIA support and open API for real interoperability between Honeywell and other manufacturers' IP-enabled security devices. Refer to the Honeywell Open Technology Alliance [http://www.security.honeywell.com/hota/] to learn more about our open and integrated solutions.

Accessories	
Housing and Mounts	
HD4DIP-PK	Pendant Mount Bracket
HD4DIP-WK	Wall Mount Bracket

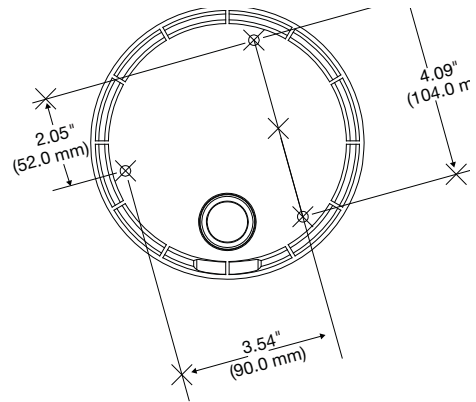
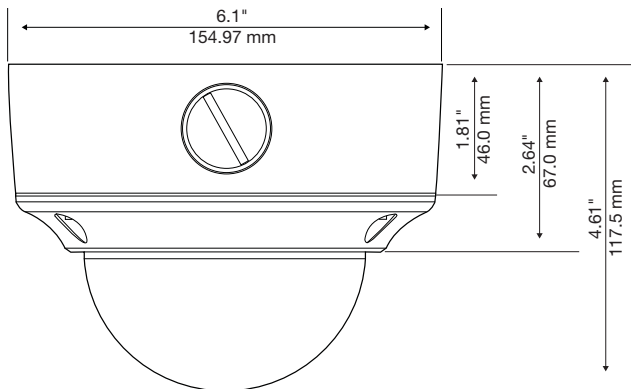

Ordering	
HD55IP	Network, Day/Night Rugged Fixed Dome, 1/4" Progressive Scan, CMOS, 720p Resolution Camera, 3.3-12 mm VFAI, 24 VAC or PoE IEEE 802.3af Class 1, H.264, NTSC
HD55IPX	Network, Day/Night Rugged Fixed Dome, 1/4" Progressive Scan, CMOS, 720p Resolution Camera, 3.3-12 mm VFAI, 24 VAC or PoE IEEE 802.3af Class 1, H.264, PAL

NOTE: Honeywell reserves the right, without notification, to make changes in product design or specifications.

Automation and Control Solutions

Honeywell Systems
 2700 Blankenbaker Pkwy, Suite 150
 Louisville, KY 40299
 1.800.796.2288
www.honeywell.com

L/HD55IP/D
 August 2011
 © 2011 Honeywell International Inc.

