

HCM574E

HIGH RESOLUTION BLACK AND WHITE CAMERA

Honeywell's HCM574E black and white camera is ideal for surveillance applications with limited light conditions. Designed for maximum value, the HCM574E saves you time and money through its easy installation and reliable performance. This camera's off-the-shelf feature sets are developed for sharp picture quality, and they require little to no adjustment once installed.

The HCM574E supports direct-drive and drive-style Auto Iris lenses to ensure video quality in changing light conditions. Regardless of lens type, attachment is simple with a built-in C/CS mounting ring and four-pin Auto Iris connector standard. Power connection is also a snap with built-in push terminals that save installation time and eliminate the need for a screwdriver.

The HCM574E includes an automatic electronic shutter for light level changes and an automatic backlight compensation option for viewing objects in the foreground with bright light in the background. The HCM574E produces 580 TV lines of resolution down to 0.15 lux.

Market Opportunities

The Honeywell HCM574E is designed for general cost effective high resolution surveillance applications where object identification and recognition are required in low light applications. This includes general indoor and outdoor surveillance applications in retail, educational, financial, and other commercial markets. For extremely dark applications the HCM574E can take advantage of external infrared illumination to further improve low light sensitivity.

Features

- 1/3" CCD with DSP
- 580 TV lines of resolution
- Low-light performance 0.15 lux (F1.2)
- Automatic Backlight Compensation (BLC)
- Automatic Electronic Shutter (AES)
- 12 VDC/24 VAC with line lock, phase adjustable
- C/CS lens mount
- DC, Video and Manual Iris lens support



HCM574E

www.honeywellvideo.com

SPECIFICATIONS

Operational	
Video Standard	EIA, CCIR
Scanning System	525/60 lines (EIA) 625/50 lines (CCIR)
Image Sensor	1/3" Interline Transfer CCD
Number of Pixels (H x V)	768 x 494 (EIA) 752 x 582 (CCIR)
Minimum Illumination	0.15 lux @ F1.2 (50 IRE)
Horizontal Resolution	580 TVL
Video Output	1.0 Vp-p @ 75 Ohms
Sync System	12 VDC: Internal 24 VAC: Line lock, Internal
S/N Ratio	50 dB (AGC off)
Auto Gain Control	High/Low
ALC	Adjust (with direct drive Auto Iris lenses)
Automatic Electronic Shutter	1/60 – 1/100,000 sec
Line Lock Phase Adjust	Adjustable line lock vertical phase
BLC	On/off, selectable
Electrical	
Input Voltage	12 VDC/24 VAC
Input Range	10 - 14 VDC, 20 - 28 VAC
Power Consumption	3.2 W (max)
Mechanical	
Dimensions (W x H x D)	2.27" x 2.57" x 5.56" (57.9 mm x 65.2 mm x 141.2 mm)
Weight	1.5 lb (0.68 Kg) camera only
Construction	Housing: Aluminum Finish: Cool gray powder coat
Camera Mount	1/4 – 20 UNC (top and bottom)
Lens Mount	C/CS adjustable mounting ring
Connector	Video Output: BNC connector Lens: 4-pin connector Power Input: Push terminals with ground
Power Indicator	LED
Environmental	
Temperature	Operating: 14°F to 122°F (-10°C to 50°C) Storage: -4°F to 140°F (-20°C to 60°C)
Relative Humidity	20% to 80%, non-condensing

Regulatory			
Emissions	FCC, CE (EN55013)		
Immunity	CE (EN50130-4)		
Safety	EU: 73/23/EEC LVD		
Accessories:			
Recommended Lens Options			
HLD25V6F12L	2.5 – 6 mm, F1.2, DC Auto Iris lens		
HLD28V8F95L	2.8 – 8 mm, F0.95, DC Auto Iris lens		
HLD27V13DNL	2.7 – 13.5 mm, F1.3, Aspherical Vari-focal lens		
HLD5V50F13L	5.0 – 50 mm, F1.3, DC Auto Iris lens		
Housings and Mounts			
HBC5WT	Wall/Ceiling Mount Bracket		
HHC12 Series	Environmental Housing		
Transformers			
HPT2420	24 VAC, 20 VA Class 2 plug-in with thermal cut-out		
HPT12DC500	12 VDC, 500 mA plug-in regulated 2.1 mm coaxial plug UL Listed/CSA Certified		
Power Supplies			
UL Listed	Fused	Smart Fused	Description
HPTV2404UL	HPTV2404	HPTV2404CB	4 A, 4 Output
HPTV2408UL	HPTV2408	HPTV2408CB	4 A, 8 Output
HPTV2416UL	HPTV2416	HPTV2416CB	8 A, 16 Output

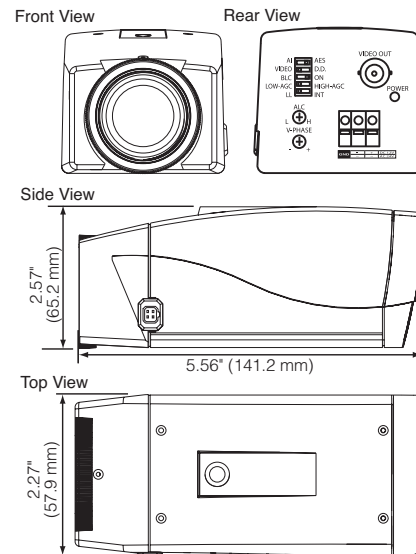

Ordering	
HCM574E	1/3" High Resolution B/W Camera with DSP, 580 TVL, 12 VDC/24 VAC, EIA
HCM584EX	1/3" High Resolution B/W Camera with DSP, 580 TVL, 12 VDC/24 VAC, CCIR
HCM585EX	1/3" High Resolution B/W Camera with DSP, 580 TVL, 230 V, CCIR

NOTE: Honeywell reserves the right, without notification, to make changes in product design or specifications.

Honeywell Security

Honeywell Video Systems
2700 Blankenbaker Pkwy, Suite 150
Louisville, KY 40299
1.800.796.CCTV
www.honeywell.com

HV05257
L/HCM574E/D
August 2006
© 2006 Honeywell International Inc.

Honeywell