

HD45IP

equiP® SERIES 720p VFAI LENS DAY/NIGHT H.264 FIXED INDOOR MINIDOME IP CAMERA

In Honeywell's equiP Series of IP-based products, the HD45IP is a 720p resolution, Day/Night fixed indoor minidome network camera engineered to provide extremely crisp images at minimal bandwidth. The HD45IP provides 720p resolution at full frame rate. Progressive scan technology and 2D edge enhancement provide outstanding clarity and definition. Digital Noise Reduction results in significant storage savings without sacrificing image quality in low light. The 1/4" progressive scan CMOS sensor offers the latest in digital video surveillance technology with accurate color rendition under a wide variety of lighting conditions. The HD45IP also supports the PSIA specification for interoperability between network video products.

The compact, one piece design provides fast and easy installation in any indoor application. The camera comes complete for surface mounting and an optional wall/pendant mount kit is available.

A 3D axis gimbal capable of 360° of pan, 180° of tilt and 360° of horizontal rotation simplifies mechanical camera adjustment. The Varifocal Auto Iris lens allows the field of view to be adjusted to suit the scene requirements, and an onboard analog output allows the installer to connect a local test monitor while adjusting the scene.

A powerful and intuitive web client allows fine tuning of the camera and the auto iris levels.

The HD45IP supports dual video streams and multiple compression formats with frame rates up to 30 frames per second (25 fps for PAL systems). The compression parameters for the two video streams are independently configurable. The primary stream is dedicated to H.264. The secondary stream can be configured for H.264 or MJPEG. A third analog stream can be utilized as a backup or for local viewing. It is also valuable when retrofitting onto an existing analog input DVR or encoder (full resolution not available).

With built-in low current Power over Ethernet (IEEE 802.3af), power is supplied to the camera using standard network cabling, eliminating the need for a separate power supply and associated wiring. In situations where PoE support is not available, the unit can also be powered directly from 24 V AC.

Market Opportunities

The HD45IP is perfect for installations where excellent picture clarity at minimal bandwidth is required. At three times the resolution of standard analog cameras, yet with similar bandwidth requirements, the HD45IP can be retrofitted on many existing DVR/NVR installations without requiring additional storage.

Features

- Outstanding image quality, 720p (1280x720) resolution
- 30 fps (25 fps PAL) progressive scan
- Day/Night, 3.3-12 mm VFAI lens
- Camera tamper detection
- Video motion detection
- Selectable compression formats: H.264 or MJPEG
- PSIA support
- Dual digital video streams, independently configurable, H.264 and/or H.264/MJPEG
- Remote firmware updates
- Supports both dynamic and static IP address assignment
- Includes advanced IP locator software to make system setup easy
- Web server for remote setup of camera video and network parameters
- Choice of 24 V AC or PoE IEEE 802.3af power inputs
- Wall/pendant mount kit available



SPECIFICATIONS

Like all cameras in the equip® Series of IP-based products, the HD45IP network camera uses Honeywell technology for video motion detection, tamper detection, remote firmware updating and for secure storage of all camera settings. Video motion detection recognizes object motion within the field of view; then a simple on-screen notification alerts the user. Camera tamper detection notifies the user when a camera's field of view is altered, blinded, or blurred. This ensures the video's integrity and alerts the customer to either a live event or a system problem that is causing disruption to the video stream. Honeywell's technology also allows users to remotely upload firmware to the camera. Setup is quick and easy and can be customized through a web client or from an NVR or DVR. The built-in web server provides password-protected access to the camera's video and network setup.



SYSTEM DIAGRAM

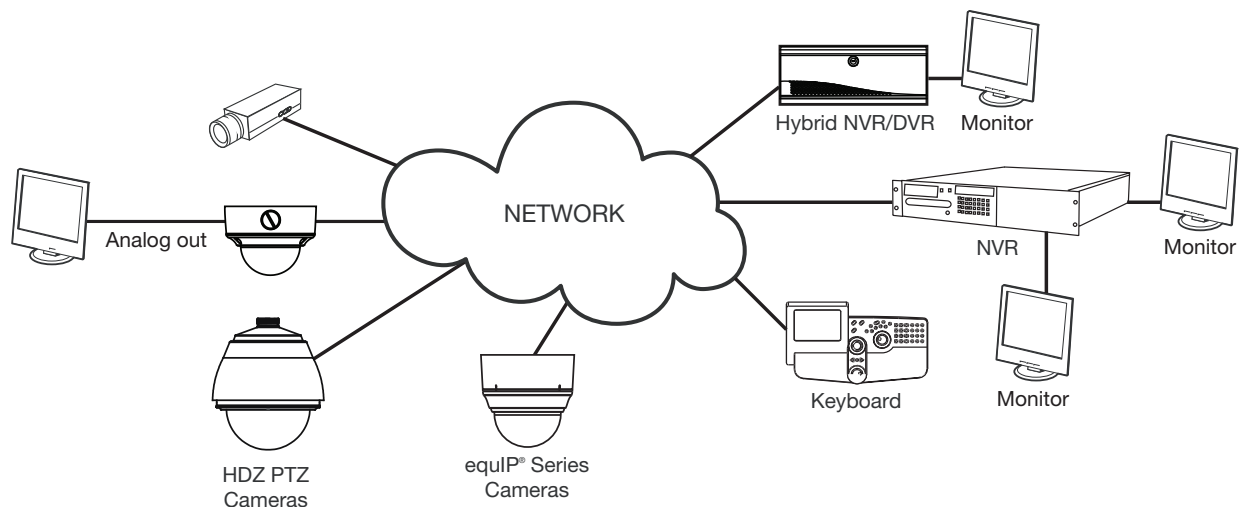

SPECIFICATIONS

Operational	
Video Standard	NTSC, PAL
Scanning System	Progressive scan
Image Sensor	1/4" CMOS
Number of Pixels (H x V)	1280x720
Minimum Illumination	0.25 lux @ 50 IRE, F1.6 0.11 lux @ 30 IRE, F1.6
Automatic Lens Control	DC Iris Level 1-25
Video Output (Aux)	1.0 Vp-p @ 75 ohms
S/N Ratio	50 dB or more (AGC off)
Auto Gain Control	Off/On, selectable (10-40 dB)
Automatic Electronic Shutter	1/60-1/24,500 sec (NTSC) 1/50-1/24,500 sec (PAL)
Lens Type	3.3-12 mm Varifocal Auto Iris, F1.6
White Balance	AWC, AWC Push, Manual
Electrical	
Input Voltage	24 V AC, PoE IEEE 802.3af
Input Range	17-28 V AC
Surge Suppression	1.5 kW transient
Power Consumption	3.5 W (max) 24 V AC PoE: PD Type 1, Class 1
Mechanical	
Dimensions (W x H)	4.9" x 4.9" (125.1 mm x 123.7 mm)
Weight	1.0 lb (0.45 kg) camera only
Construction	Housing: Polycarbonate Finish: Matte texture, off-white
Connector	Video Output (AUX): 2-pin Molex connector Power Input: Removable screw block Network: RJ45 connector

Environmental			
Temperature	Operating: 14°F to 122°F (-10°C to 50°C) Storage: -40°F to 158°F (-40°C to 70°C)		
Relative Humidity	0% to 85%, non-condensing		
IP Specifications			
Video Compression	Dual stream H.264 and MJPEG		
Resolution	H.264 Bitrate (Typical)*	Frame Rate	Storage/Day (GB)
1280x720	1.8 Mbps	30/25	18.98
800x450	1.2 Mbps	30/25	12.65
640x360	0.6 Mbps	30/25	6.33
320x180	0.21 Mbps	30/25	0.89
Frame Rate NTSC/PAL	Up to 30/25 fps video in all resolutions		
Video Streaming	Dual streaming: H.264 and MJPEG. Controllable frame rate and bandwidth. Constant or variable bit rate		
Security	Multiple user access levels with password protection		
Users	1 Administrator, 3 Guests		
Video Access from Web Browser	Full control of all camera settings available to administrator		
Minimum Web Browsing Requirements	Pentium IV CPU 3.1 GHz or faster 1 GB RAM (32-bit) or 2 GB RAM (64-bit) Windows XP® SP3, Windows 2003 Server R2 (32-bit), Windows 7 (32-/64-bit), Windows 2008 Server (32-/64-bit), Windows 2008 R2 (64-bit) Internet Explorer 6, 7, 8, or 9		
Installation and Management Maintenance	Honeywell IP Utility software identifies the IP address, checks status of device, firmware upgrades over HTTP		
Supported Protocols	HTTP, TCP, RTSP, RTP, UDP, ARP, DNS, RTCP, FTP, ICMP, DHCP, Bonjour, IGMP, Telnet		
Standards	PSIA support		
Regulatory			
Emissions	FCC part 15B, CE (EN55022)		
Immunity	CE (EN50130-4)		
Safety	EU: EN60950-1 North America ETL listed to UL/CSA 60950-1		

*Actual bitrate is scene and motion dependent.

SPECIFICATIONS

System Integration
Open IP Integration
PSIA support and open API for real interoperability between Honeywell and other manufacturers' IP-enabled security devices. Refer to the Honeywell Open Technology Alliance (http://www.security.honeywell.com/hota/) to learn more about our open and integrated solutions.

Accessories	
Housing and Mounts	
HD3-MK1	Wall/Pendant Mount Kit, Off White

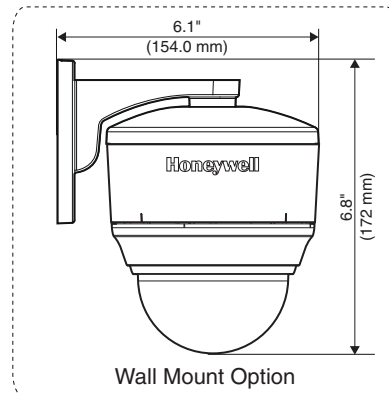
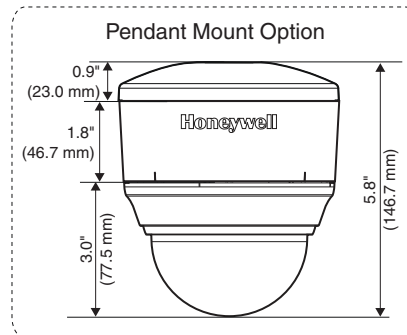
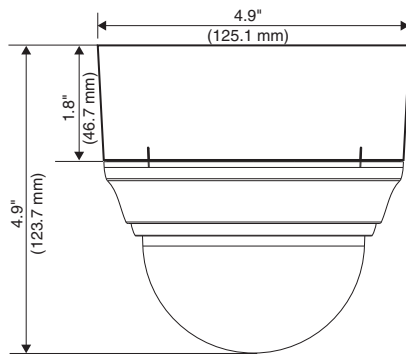

Ordering	
HD45IP	Network Day/Night Fixed Indoor Minidome Camera, 1/4" Progressive Scan, CMOS, 720p Resolution, 3.3-12 mm VFAI Lens, 24 V AC or PoE IEEE 802.3af, H.264

NOTE: Honeywell reserves the right, without notification, to make changes in product design or specifications.

For more information:

www.honeywell.com/security

Automation and Control Solutions

Honeywell Security Products Americas
 2700 Blankenbaker Pkwy, Suite 150
 Louisville, KY 40299
 1.800.323.4576
www.honeywell.com

